



## LASER SPOT TRACKER 1ST GENERATION

The 1st Gen. Laser Spot Tracker (LST) is a gimbal mounted system designed for airborne detection of STANAG 3733 Band I and II encoded 1064nm pulsed lasers.

The system is designed around a flexible chipset that can be fitted to various applications and space envelopes by appropriate design of the optical system, detector, and chipset packaging (electrical and mechanical). Parameters and description below are for the standard small outline application, and can be significantly improved by provision of a larger aperture.

Standard communication with the unit is via an RS422 link, which provides a moding, setup, test, and reporting interface. Message structure provides comprehensive control of TNR and pulse detection characteristics. Other interface designs can be provided if required.

### KEY BENEFITS

- Compact and lightweight module
- Single LRU for simple installation and maintenance
- In service and fully operational.

### LASER SPOT TRACKER CONFIGURATION

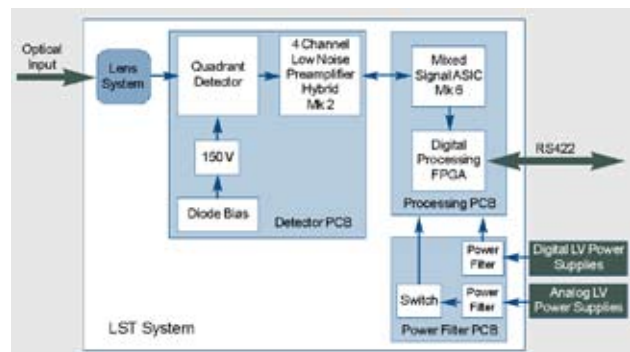



Laser centre of excellence

**TECHNICAL SPECIFICATIONS**

**STANAG Band I & II**

**Spectral Response**

1.06 µm

**Optical Clear Aperture**

50 mm

**Field-of-View**

9° ±0.25°

**Boresight Accuracy**

1.0 mRad per axis at 10 x Minimum Detectable Signal (MDS)  
 Last Pulse Logic (120 ns min separation)  
 Full duplex 1Mbps RS422 communications link

**Dynamic Range**

MDS to 65,000 x MDS (full specification)  
 80,000 x MDS (reduced functionality)

**Sensitivity**

Typically < 30 nW/cm<sup>2</sup>  
 (dependant on available aperture)

**False acquisition**

1 per hour

**Full on-board BIT**

As standard

**Power Supply**

±5 V, +12 V Analog, +5 V Digital

**Power Dissipation**

6W Typical

**Weight**

600 g

**Size**

100 x 120 x 140 mm

**Electrical Requirements**

+12 V Analog: +12 V DC ±5%, 350 mA maximum, low noise and ripple  
 +5 V Analog: +5 V DC ±5%, 650 mA average, low noise and ripple  
 -5 V Analog: -5 V DC ± 5%, 75 mA average, low noise and ripple  
 +5 V Digital: +5 V DC ±5%, 200 mA average, low noise and ripple

**Power Consumption**

6 W typical  
 8.8 W max

**LASER CENTRE OF EXCELLENCE**

Officially opened in May 2004, the design of the laser centre of excellence has been based on extensive research into manufacturing best practice within the defence and commercial sectors.

**EXPERIENCE**

We have a reputation for providing customers with the best in high performance and cost-effective technology for laser requirements. More than 5000 LST and receivers have been produced as integral parts of in-house laser systems or as standalone units for integration into electro-optic targeting systems.

We are currently under contract to develop the next generation of laser technology within the F-35 Joint Strike Fighter electro-optic targeting system.